

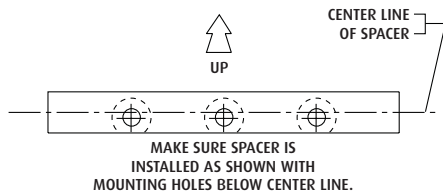

Safety Technology International, Inc.
 2306 Airport Road • Waterford, Michigan 48327-1209
 Phone: 248-673-9898 • Fax: 248-673-1246
 Toll Free: 800-888-4784 • E-mail: info@sti-usa.com
 Web: www.sti-usa.com

Safety Technology International (Europe) Ltd.
 Unit 49G Pipers Road • Park Farm Industrial Estate • Redditch
 Worcestershire • B98 0HU • England • Tel: 44 (0) 1527 520 999
 Fax: 44 (0) 1527 501 999 • Freephone: 0800 085 1678 (UK only)
 E-mail: info@sti-europe.com • Web: www.sti-europe.com

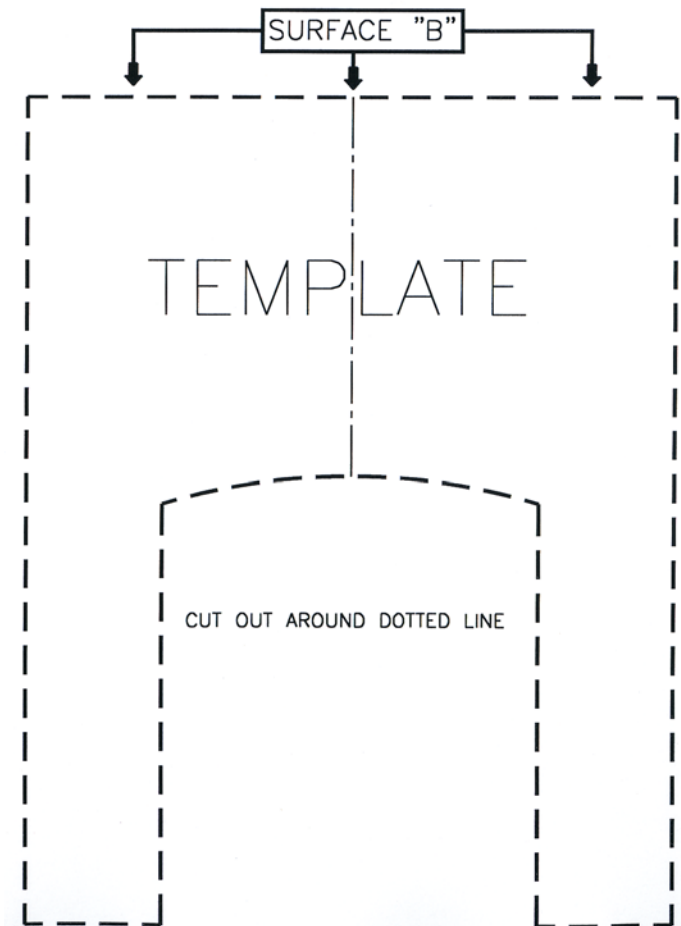
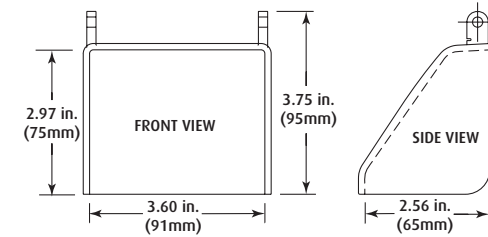
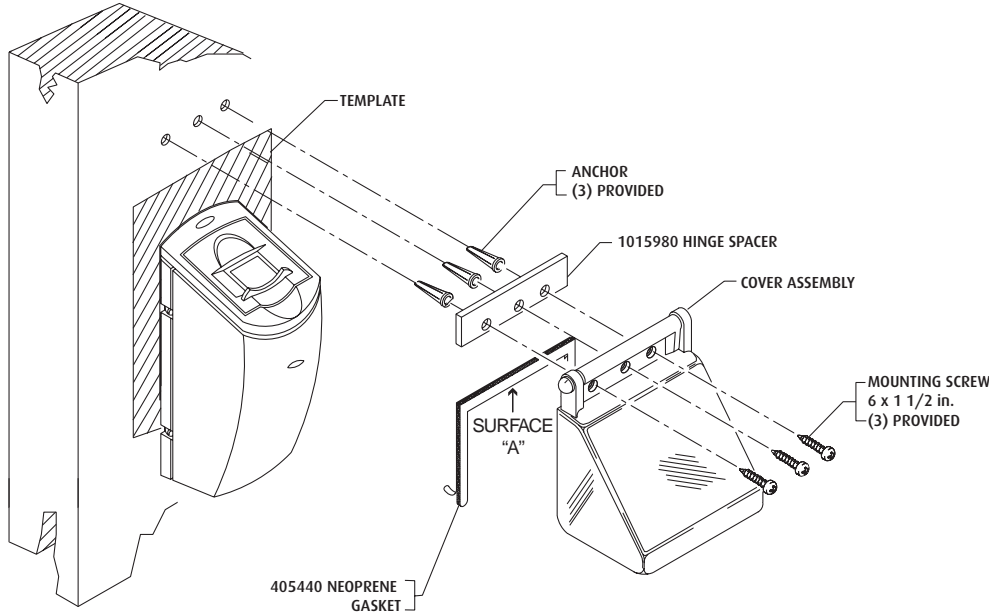

SPACER ORIENTATION

INSTALLATION:

1. Cut out template and place it around unit as shown.
2. Remove backing paper from gasket and center gasket around template with surface "A" lying on surface "B" of template.
3. Using spacer as drill template mark and drill three (3) 3/16 in. diameter holes. Complete installation as shown.

OPTIONAL: If anchors are not required, use spacer as template, mark and drill (3) holes using a #32 drill bit.

CLEANING INSTRUCTIONS

Rinse with water to remove abrasive dust and dirt. Wash with soap or mild detergent using a soft cloth. DO NOT SCRUB OR USE BRUSHES OR ABRASIVES. Rinse once more, then dry with a soft cloth or chamois. To remove grease or wet paint, rub gently with a damp cloth thoroughly with naphtha. Then wash and rinse. DO NOT USE RAZOR BLADES.

INSTALLATION OF BIO-6514 PROTECTIVE COVER

All specifications and information shown were current as of publication, and are subject to change without notice.